

# SCM-2

## Suspended Ceiling Replacement Tile

### Product Features:

For use with 2' x 2' or 2' x 4' ceiling grids

Ceiling tile can be rotated for 9 possible mounting locations

Can be used with standard 1.5" NPT pipe or VMP ceiling masts

Includes 30 feet of tie wire

Four integrated standard electrical KOs

Load capacity - 200 lbs

White powder coat finish

### Product Specifications:

*(for Architects & Engineers)*

The suspended ceiling replacement tile for a 2' x 2' ceiling grid shall be the Video Mount Products (VMP) part number SCM-2. The suspended ceiling replacement tile shall be primarily constructed of formed steel and include spot and arc welds. The suspended ceiling replacement tile shall include tie wire and hardware to attach the tie wire to the most common surfaces located above suspended ceilings.

The suspended ceiling replacement tile shall be able to accommodate 1.5" NPT as well as any VMP ceiling mast within its weight capacity. The suspended ceiling replacement tile shall have 3 ceiling mast mounting locations and the tile shall be able to rotate providing a total of 9 locations. The suspended ceiling replacement tile shall have 4 junction box mounting locations. The load capacity shall be 200 lbs.

### Video Mount Products

345 Log Canoe Circle

Stevensville, MD 21666

Toll Free: 877.281.2169

Telephone: 410.643.6390

Facsimile: 410.643.6615

[www.videomount.com](http://www.videomount.com)

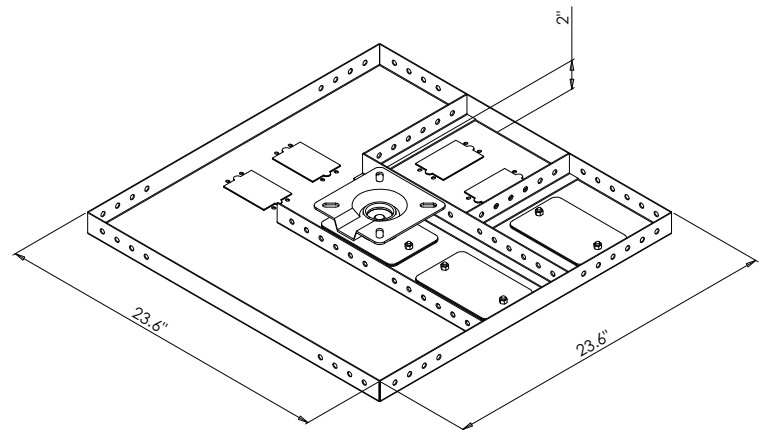

**VMP**  
VIDEO MOUNT PRODUCTS